

**SOIL EROSION AND SEDIMENT POLLUTION CONTROL PLAN  
FOR USE WITH OIL WELL DEVELOPMENT ON  
Lot 8, Wells 8-43, 8-45, 8-55, 8-66, 8-72, New Roads / Transmission  
Lines, and Future Wells.**

For

***Duhring Resource Company***

The Project is in Sheffield Township, Warren County, Pennsylvania

**1. General Information**

**Date:** March 19, 2007

**Landowner:** Allegheny National Forest  
29 Forest Service Drive  
Bradford, PA 16701

**Lease Owner:** Duhring Resource Company  
7 Branch Street  
Warren, Pennsylvania, 16365  
(814)723-3445

**Earthmoving**

**Contractor:** To Be Determined

**Plan Preparer:** Hampson Surveying  
4 Harmer Street, Box 14  
Warren, PA 16365

**Project Description:** Duhring Resource Company is planning to develop five oil well locations and access roads on the lands of the Allegheny National Forest, Lot 8 in Sheffield Township, Warren County, Pennsylvania. The disturbed area for the project will be kept to a minimum. Soil disturbances will occur while building a well locations and access roads. Wherever possible, existing roads and locations will be utilized to prevent earth disturbance.

**Time Table:** Locations and wells will be completed when weather conditions, earth moving crews, drilling schedules, and availability of drilling permits will allow operations.

## **2. Map of the Proposed Project Area.**

A site location map with site locations is attached to this plan. The site location map is a digitized copy of the U.S. Geological Survey Topographic Map. The site plan shows roads, streams, buildings, project boundaries, existing contours, and proposed locations.

## **3. Soils of the Project Area.**

A soils map of the project area is attached to this plan. Soil locations and boundaries were digitized from the Soil Survey of Warren and Forest Counties, Pennsylvania, United States Department of Agriculture, Soil Conservation Service. The soils impacted by this project are as follows.

### **GpF-Gilpin soils, 25 to 60 percent slopes.**

These steep and very steep soils are on hillsides of the uplands not subjected to glacial action. Gilpin soils comprise approximately 80 percent of the map unit. Individual areas are long and relatively narrow and are 10 to 200 acres.

Some areas have stones which are 10 to 36 inches in diameter and which cover 3 to 15 percent of the surface. Other areas are not stony or are made up of both stony and nonstony soils. These soils have a surface layer of channery silt loam and channery loam. The present and expected uses of these steep and very steep soils are so similar that separation of stony and nonstony soils is not important to the objectives of the survey.

Typically, the surface layer is black and grayish brown channery silt loam that is 7 inches thick. The subsoil is yellowish brown channery silt loam and yellowish brown shaly silt loam to a depth of 27 inches. The 3-inch thick substratum is brown very shaly silt loam. Light olive brown siltstone and sandstone bedrock is at a depth of 30 inches.

Included with these soils in mapping are areas of very stony Hazleton and Ernest soils. The Hazleton soils have slopes of 40 to 80 percent.

These Gilpin soils have moderate permeability and moderate available water capacity. Surface runoff is very rapid. In unlimed areas reaction is extremely acid to strongly acid throughout.

Most areas of the Gilpin soils are used for woodland.

These soils are not being used for cultivated crops or for pasture because of steep and very steep slopes and stones on the surface. They are well suited to woodland, and potential productivity of the soil for trees is high. The steep and very steep slopes and the very stony surface interferes with harvesting and planting by machine.

The steep and very steep slopes and the stones on the surface, where they are present, are major limitations for most urban uses, especially for onsite sewage disposal. This soil is in capability subclass Vlle and has a woodland ordination symbol of 2r.

**EvD-Ernest very stony silt loam, 0 to 25 percent slopes.**

This deep soil is moderately well drained and nearly level to moderately steep. It is on foot slopes and along the sides of drainageways that have not been subjected to glacial action. Slopes are concave and smooth and are 200 to 600 feet long. Individual areas are oblong and are 5 to 60 acres. Large stones cover about 3 to 15 percent of the surface.

Typically, the surface layer is very dark grayish brown silt loam about 4 inches thick. The subsurface layer is brown silt loam to a depth of 8 inches. The subsoil extends to a depth of 42 inches. The upper 8 inches is yellowish brown silt loam. The next 13 inches is mottled brownish yellow and brown channery silt loam and channery silty clay loam. The lower 13 inches is a fragipan of mottled brown, firm and brittle channery silty clay loam. The substratum is brown channery silty clay loam to a depth of 60 inches.

Included with this soil in mapping are some areas of the Brinkerton soils and the nonstony Ernest soils. Inclusions make up about 10 percent of the unit.

The Ernest soil has numerous, large stones on the surface. It has moderately slow permeability in the fragipan and substratum and moderate available water capacity. In unlimed areas reaction is very strongly acid or strongly acid throughout. A seasonal high water table is within 18 to 36 inches of the surface for part of the year. Surface runoff is slow to rapid. Rooting depth is restricted by the fragipan and by the seasonal high water table.

This soil is mostly in woodland. It is too stony for crops or pasture.

This soil is not being used for cultivated crops or for pasture because of large stones on the surface. Removing the trees and stones and reducing the water table to cultivate crops or pasture is usually not feasible because of the expense involved.

This soil is suited to trees, and most acreage is wooded. Potential productivity of the soil for trees is high. Rooting depth is restricted by the fragipan and by the seasonal high water table. Removal of undesirable species is a management practice that helps increase production. Equipment use is restricted for part of the year because of the seasonal high water table. The large stones on the surface interfere with harvesting and planting seedlings.

This soil has a limitation for most urban uses because of the seasonal high water table; the slope, in some places; the moderately slow permeability; and the very stony surface.

This soil is in capability subclass Vls and has a woodland ordination symbol of 2w.

### **HvF – Hazleton Very Stony Sandy Loam**

HvF-Hazleton very stony sandy loam, 25 to 80 percent slopes. This deep soil is well drained and is steep and very steep. It is on the upper part of hillsides that have not been subjected to glacial action. Slopes are convex and smooth and are 200 to 800 feet in length. Individual areas are long and normally range for 10 to 200 acres. Large stones cover about 3 to 15 percent of the surface.

Typically, this soil has a surface layer of dark gray sandy loam about 2 inches thick. The subsoil extends to a depth of 32 inches. In sequence from the top, it is dark reddish brown sandy loam to a depth of 4 inches; yellowish red channery sandy loam to a depth of 6 inches; reddish yellow channery sandy loam to a depth of 15 inches; strong brown channery sandy loam to a depth of 22 inches; and reddish yellow very channery sandy loam to a depth of 32 inches. The substratum is reddish yellow very channery coarse sandy loam. Yellowish brown sandstone bedrock is at a depth of 56 inches.

Included with this soil in mapping are some areas of nonstony Hazleton and Gilpin soils and the very stony Gilpin soil. Inclusions make up about 10 percent of the unit.

This Hazleton soil has stones on the surface and many channery fragments in the profile. It has moderately rapid and rapid permeability and moderate available water capacity. Reaction is extremely acid to strongly acid throughout. Surface runoff is very rapid.

Most areas of this soil are used for woodland. A few areas are used for pasture or recreation, or they are idle.

This soil is not suited to cultivated crops or to improved pasture because of slope and the large stones on the surface.

This soil is suited to trees, and most acreage is wooded. Potential productivity of the soil for trees is moderately high. Removal of undesirable species is a management practice that helps increase production. The steep slopes are a serious restriction for equipment. Large surface stones and slope interfere with mechanical planting of seedlings.

This soil has major limitations for most urban uses, especially for onsite sewage disposal, because of the 3 1/2 to 6 foot depth to bedrock, the slope, and the very stony surface.

This soil is in capability subclass VII<sub>s</sub> and has a woodland ordination symbol of 3r.

### **HvD-Hazleton very stony sandy loam, 8 to 25 percent slopes.**

This deep soil is well drained and is sloping and moderately steep. It is on the upper part of hillsides not subjected to glacial action. Slopes are convex and smooth and are 200 to 800 feet in length. Individual areas are long and normally range from 10 to 200 acres. Large stones cover about 3 to 15 percent of the surface.

Typically, this soil has a surface layer of about 2 inches thick. The subsoil extends to a depth of 32 inches. In sequence from the top, it is dark reddish brown sandy loam to a depth of 4 inches; yellowish red channery sandy loam to a depth of 6 inches; reddish yellow channery sandy loam to a depth of 15 inches; strong brown channery sandy loam

to a depth of 22 inches; and reddish yellow very channery sandy loam to a depth of 32 inches. The substratum is reddish yellow very channery coarse sandy loam. Yellowish brown sandstone bedrock is at a depth of 56 inches.

Included with this soil in mapping are some areas of nonstony Hazleton and Cookport soils and the very stony Cookport soil. Inclusions make up about 10 percent of the unit.

This Hazleton soil has moderately rapid and rapid permeability and moderate available water capacity. Reaction is extremely acid to strongly acid throughout. The soil has numerous large stones on the surface and many channery fragments in the profile. Surface runoff is moderately rapid to rapid.

Most areas of this soil are used for woodland. A few areas are used for pasture or recreation, or they are idle.

This soil is not being used for cultivated crops or for improved pasture because of the large stones on the surface. Removing the trees and surface stones to cultivate crops or pasture is usually not feasible because of the expense involved.

This soil is suited to trees, and most of the acreage is wooded. Potential productivity of the soil for trees is moderately high. Removal of undesirable species is a management practice that helps increase production. Equipment use is somewhat restricted on the steeper and more stony soils. Large stones on the surface and slope interfere with mechanical planting.

This soil has limitations for most urban uses, especially for onsite sewage disposal, because of the 3 1/2 to 6 foot depth to bedrock, the moderately rapid and rapid permeability, the slope, and the very stony surface.

This soil is in capability subclass VI<sub>s</sub> and has a woodland ordination symbol of 3r.

### **CvC-Cookport very stony silt loam, 0 to 15 percent slopes.**

This deep soil is nearly level to sloping and is moderately well drained. It is on broad plateaus and the upper part of hillsides not subjected to glacial action. Slopes are concave and smooth and are 200 to 1,000 feet long. Individual areas are irregularly shaped or oblong and are 5 to 250 acres. Large stones cover about 3 to 15 percent of the surface area.

Typically, the surface layer is dark brown silt loam about 3 inches thick. The subsurface layer is dark yellowish brown silt loam to a depth of 10 inches. The subsoil extends to a depth of 40 inches. The upper 6 inches is yellowish brown loam. The next 8 inches is mottled yellowish brown loam. The lower 16 inches is a fragipan of mottled yellowish brown, firm and brittle channery loam. The substratum is mottled yellowish brown very channery loam to a depth of 60 inches. Gray sandstone bedrock is at a depth of 60 inches.

Included with this soil in mapping are some areas of the nonstony Cookport soils, the Hazleton soils, and the very stony Hazleton soils. Inclusions make up about 10 percent of the unit.

This Cookport soil has slow permeability in the fragipan, moderate available water capacity, and a seasonal high water table within 18 to 36 inches of the surface for part of

the year. Reaction is very strongly acid or strongly acid throughout. Surface runoff is slow to moderately rapid. Rooting depth is restricted by the fragipan and by the seasonal high water table.

This soil is mostly in woodland. A few areas are used for pasture or recreation, or they are idle. This soil is not being used for cultivated crops or for improved pasture because of the large stones on the surface. Removing the trees and surface stones is not usually feasible because of the expense involved.

This soil is suited to trees, and most acreage is wooded. Potential productivity of the soil for trees is

high. Rooting depth is restricted by the fragipan and by the seasonal high water table. Removal of undesirable species is a management practice that helps increase production. Equipment use is restricted for a part of the year because of the seasonal high water table. The large stones on the surface interfere with harvesting and planting seedlings by machine.

This soil has major limitations for most nonfarm uses, especially for onsite sewage disposal, because of the seasonal high water table, slow permeability in the fragipan, and the very stony surface.

This soil is in capability subclass VI<sub>s</sub> and has a woodland ordination symbol of 2w.

#### **4. Proposed Alterations to the Area**

Oil well locations and minimal access roads as needed. Existing roads will be reclaimed whenever possible. Locations will be built using variations of the Sample Plans for a Single well included in the appendix. Roads and structures needed to support the roads should be built referencing the typical drawings in the Appendix as a reference.

#### **5. Amount of Runoff**

The amount of runoff from the project area depends on vegetation, soil type, and the area involved. Assuming a ten year storm, with minimal disturbance, and typical disturbed banks at a slope of 5:1, the Rational Equation for determining peak runoff rate calculates the runoff as being minimal.

If needed, culverts will be installed according to the specifications in the appendix. Culverts will also be installed at small intermittent channels that are concentrating runoff onto access roads.

Tables in the appendix show typical water bar and typical culvert installation.

## **6. Staging of Earthmoving Activities**

This project should start sometime in the Spring of 2007. The activities to complete this project will be as follows:

1. Stabilization, if needed, of existing roads to the site.
2. Cutting of trees and shrubs to clear the location.
3. Removal and storage of topsoil from the location.
4. Digging a sump pit to collect all of the cuttings.

## **7. Temporary Erosion and Sediment Pollution Control Measures**

The following erosion control measures will be utilized on an as needed basis and according to the Sample Plans for a Single Well.

1. Rock construction entrance.
2. Straw bale barrier
3. Filter fabric fence
4. Temporary seeding
5. Water bars
6. Temporary swale
7. Sediment trap
8. Vegetative filter strip

Standard details of each control method are in the appendix.

## **8. Permanent Erosion and Sediment Pollution Control Measures**

All exposed areas, except roads, will be seeded and mulched according to the Temporary and Permanent Seeding Specifications, included in the appendix. Roads will be graveled as needed so they are permanently stabilized to prevent accelerated erosion.

## **9. Maintenance Program**

Until the site is completely stabilized, all temporary and permanent erosion and sedimentation control measures will be checked weekly, especially after a significant rainfall. All necessary repairs shall be made immediately to the control devices/measures to ensure their proper and effective working condition.

Disturbed areas to be permanently stabilized with seeding and mulch shall be checked weekly for proper vegetative growth until permanent stabilization is achieved. Temporary seeding is to be implemented in any disturbed areas uninvolved in construction for more than twenty days.

After permanent stabilization has occurred, all temporary erosion and sedimentation control devices shall be removed.

## **10. Reference**

Oil and Gas Operators Manual, publication 550-0300-001, October 30, 2001

Soil Survey of Warren and Forest Counties, Pennsylvania, United States Department of Agriculture, Soil Conservation Service

DEP Erosion and Sediment Pollution Control Program Manual, March 2000

DEP Underground Utility Line Construction, Typical Erosion and Sediment BMP's, August 1, 2001

## Appendix

## STANDARD CONSTRUCTION DETAIL #16 Rock Construction Entrance

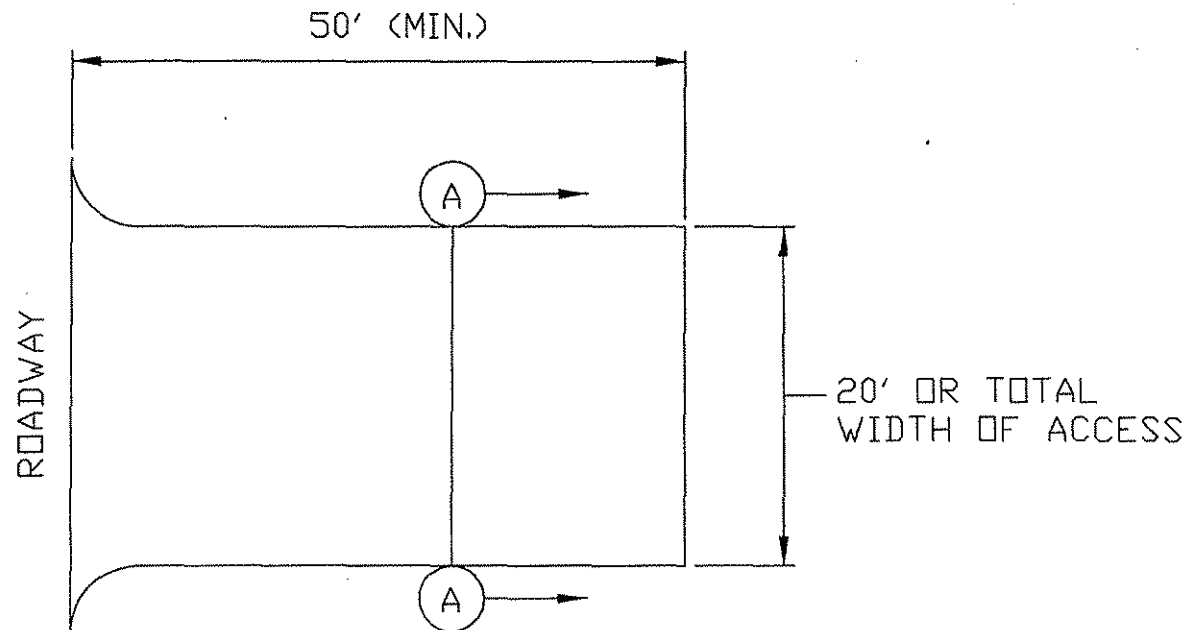

**PLAN VIEW**

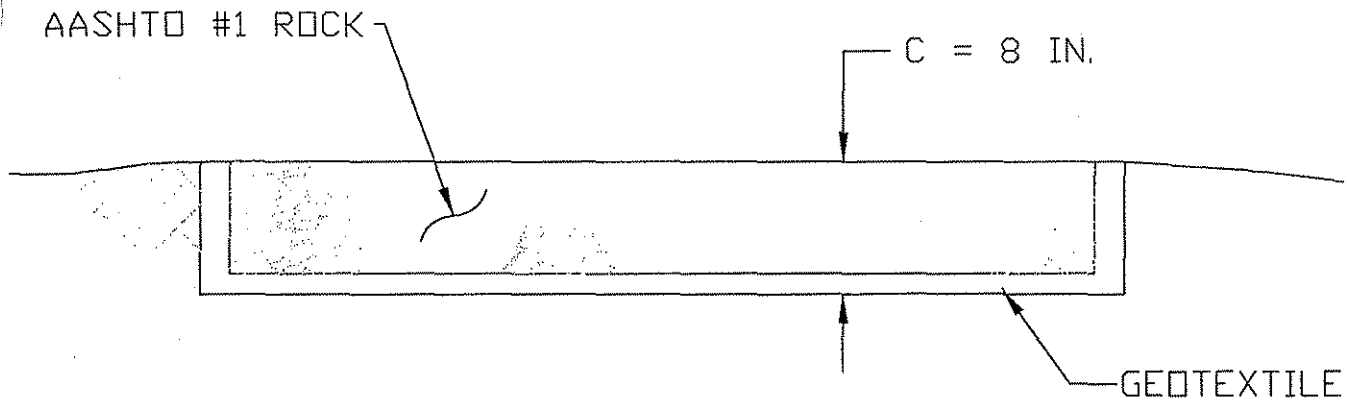

**SECTION A-A**

**MAINTENANCE:** Rock Construction Entrance thickness shall be constantly maintained to the specified dimensions by adding rock. A stockpile shall be maintained on site for this purpose. At the end of each construction day, all sediment deposited on paved roadways shall be removed and returned to the construction site.

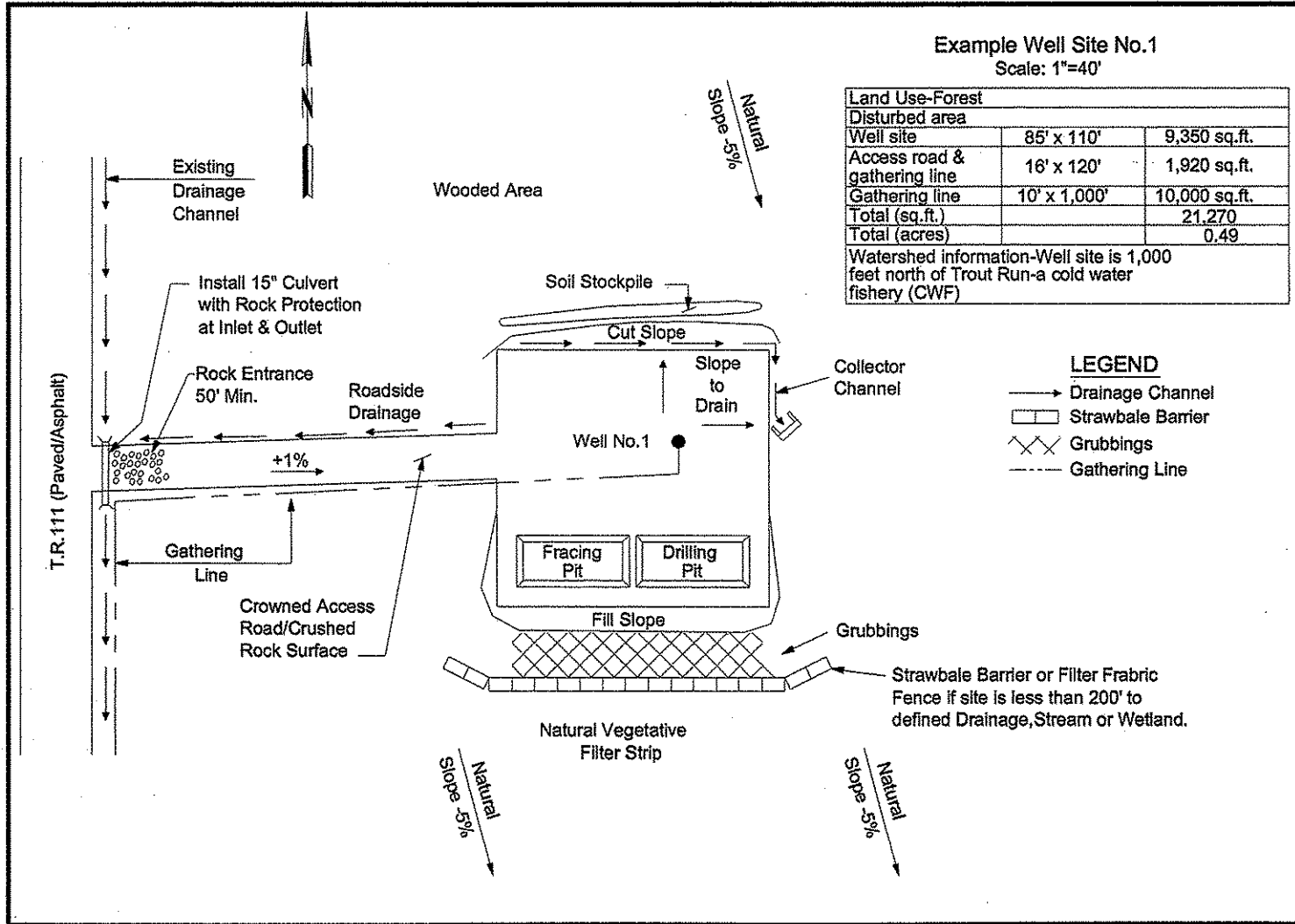

Figure 4-1 (c). Sample Plan for a Single Well

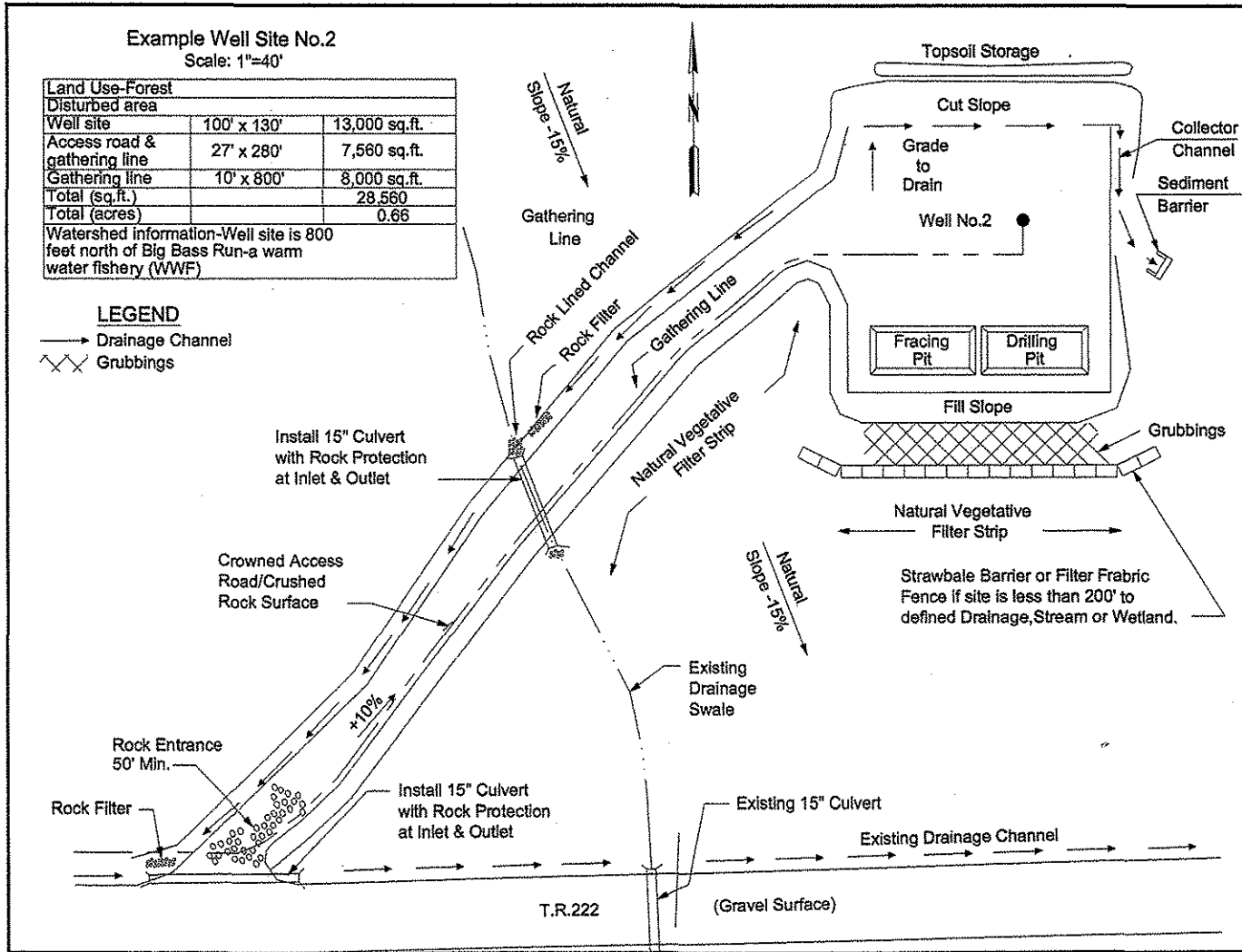

Figure 4-1 (b). Sample Plan for a Single Well

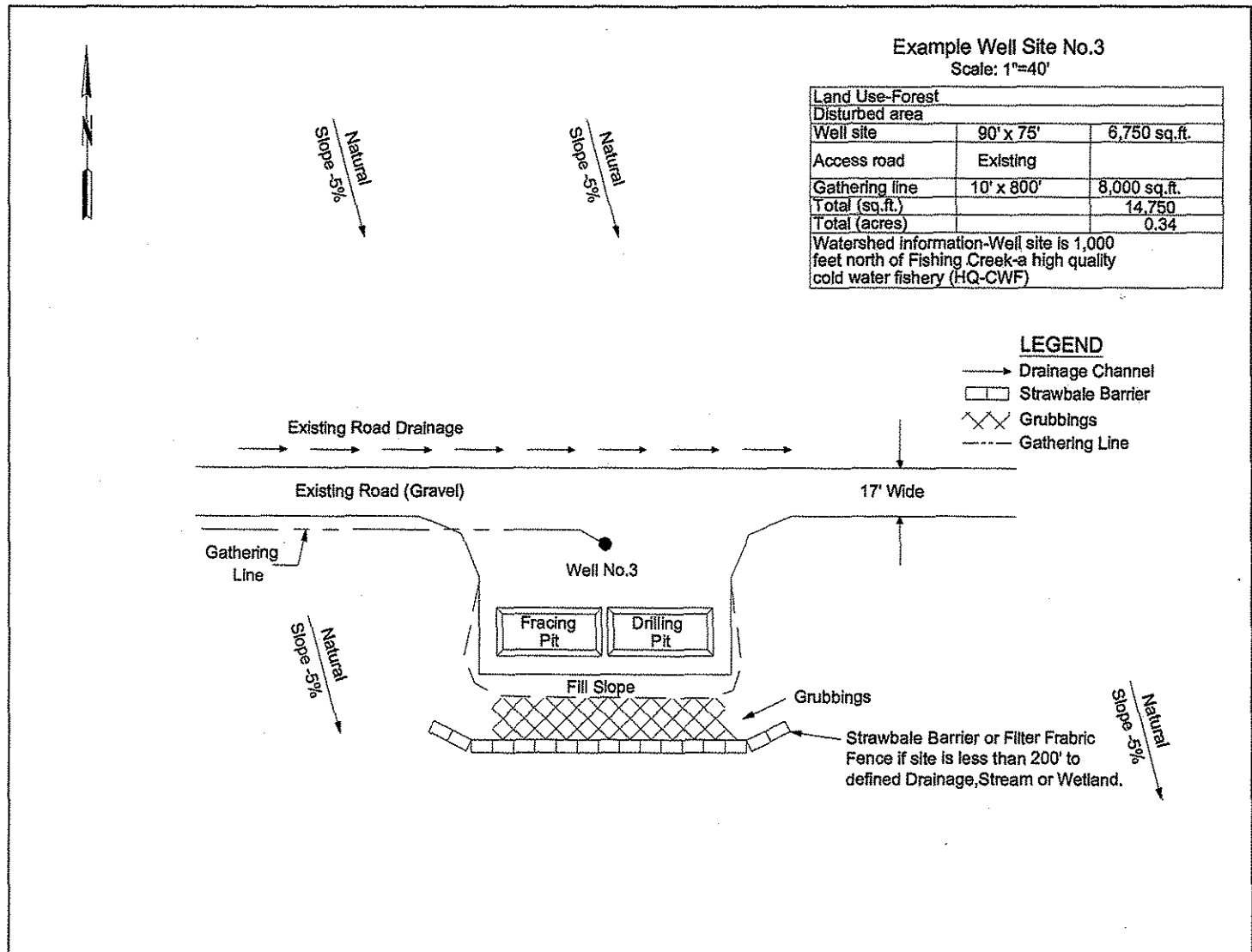

Figure 4-1 (c). Sample Plan for a Single Well

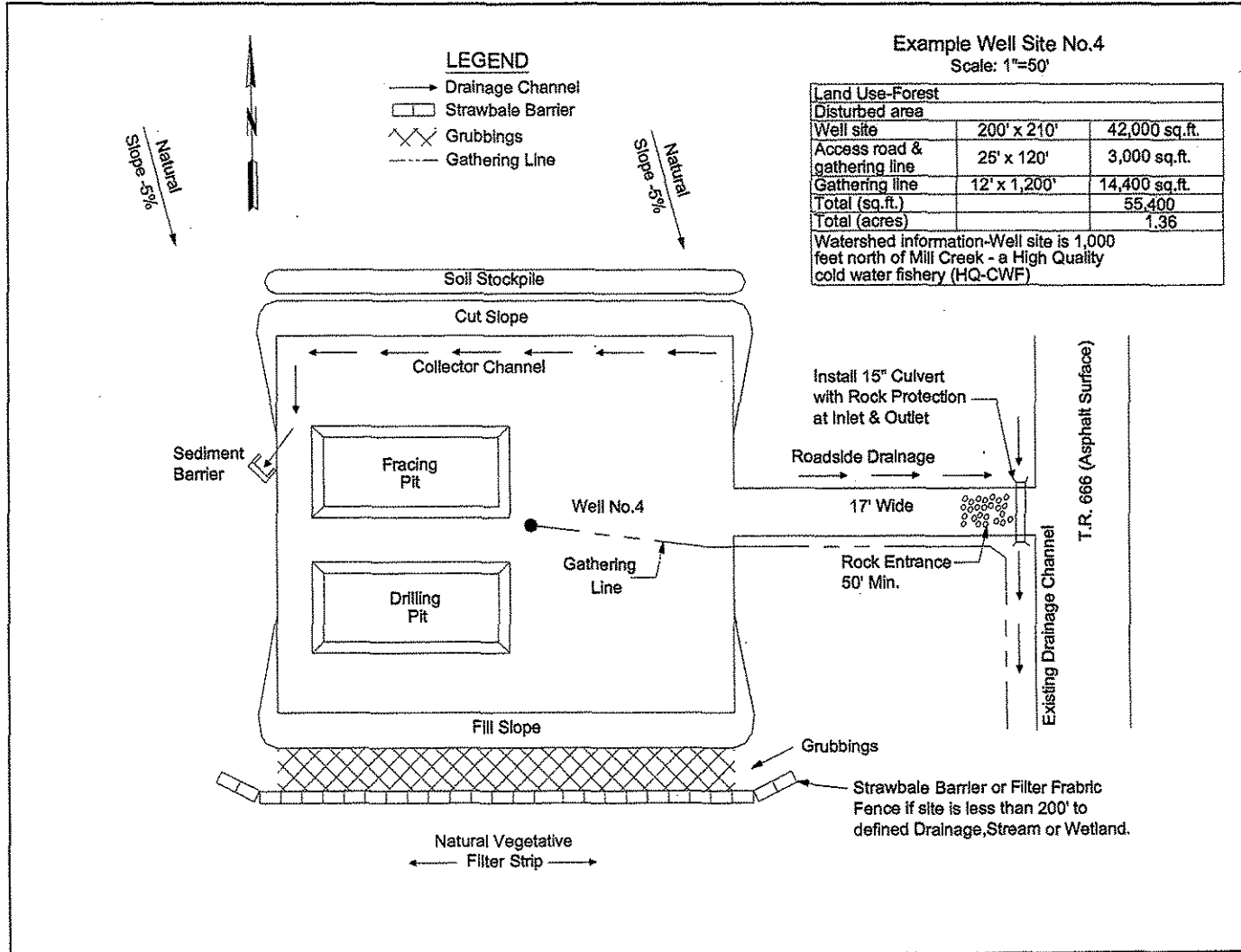

Figure 4-1(d). Sample Drawing for a Single Well

550-0300-001 / October 30, 2001 / Chapter 4, Page 20

**Table 4-5. Minimum Vegetative Filter Strip Width**

Slope of Land Between Road and Stream (Percent)	Minimum Width of Filter Strip (Feet)
0-25	50*
26-30	85
31-40	105
41-50	125
51-60	145
61-70	165

**NOTE:** If the road is located within a mapped floodway or 50 feet of the top of the stream bank (absent evidence to the contrary), an encroachment permit is required from the Oil and Gas Management Program or Conservation District if the drainage area is greater than 100 acres.

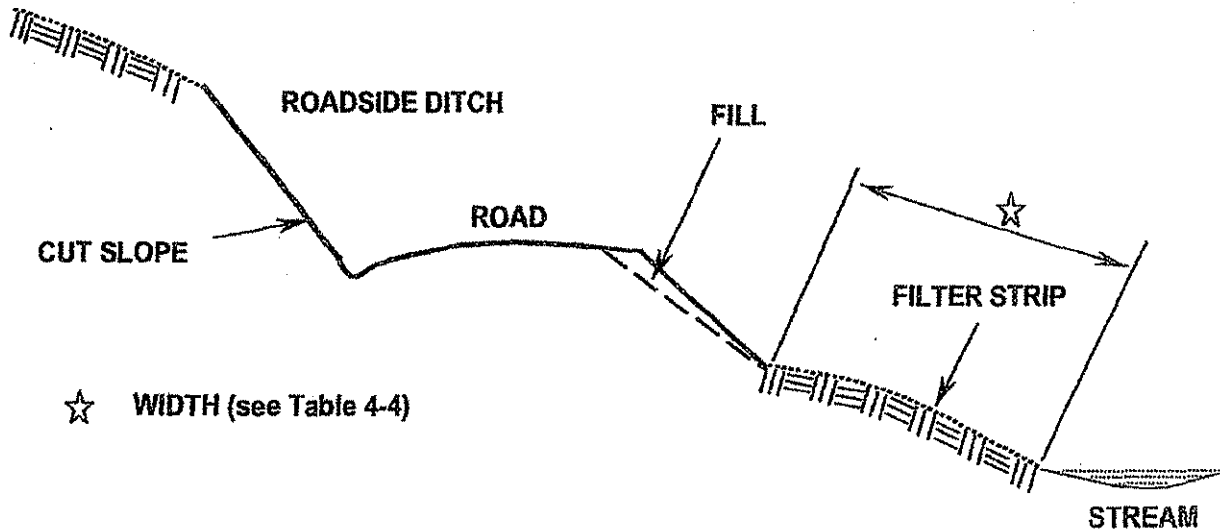

**Figure 4-4. Vegetative Filter Strip**

**Table 4-4. Maximum Slope Lengths for Filter Fabric Fence**

Slope - Percent	Maximum Slope Length (ft) Above Fence	
	18" High Fence	30" High Fence*
2 (or less)	150	500
5	100	250
10	50	150
15	35	100
20	25	70
25	20	55
30	15	45
35	15	40
40	15	35
45	10	30
50	10	25

\*Reinforced 30" high fence. See Standard Construction Details # III or # IV.

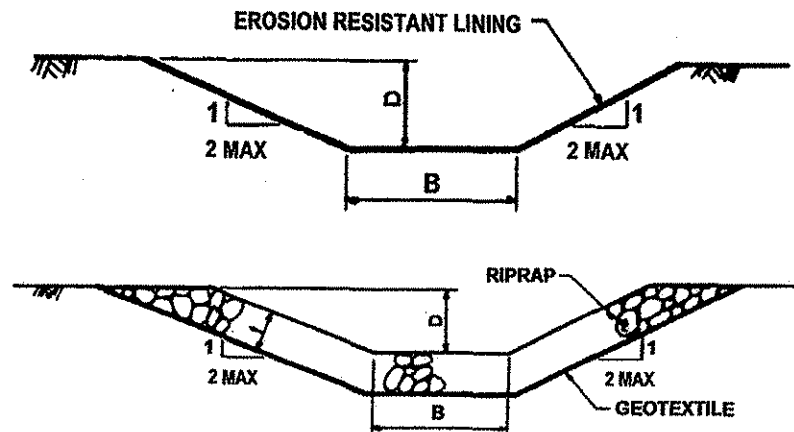

Figure 4-2. Typical Channel Cross Sections

9. **Diversion Channels and Collector Channels** - Diversion channels must be provided to collect runoff from upslope areas and divert the water around the well site. This diversion can be constructed by excavating a channel upslope of the well site, or by stockpiling the topsoil above the well site to form a berm to divert the runoff. The diversion should outlet to a level spreader or a vegetative filter strip. Another option is to install a channel at the base of the cut slope to collect the runoff before it runs onto the pad and into the drilling and fracing pits. This channel is also beneficial when springs or seeps are encountered in the cut slope. This channel should be stabilized and outlet to a level spreader or vegetative filter strip, a sediment trap or sedimentation basin.

Collector channels should be provided to collect runoff from the well site and fill slopes and convey it to a sediment trap, unless runoff from disturbed areas can be directed to the trap by some other means. These channels should be located below the disturbed areas and aligned so that positive drainage is provided to the sediment trap.

- a. Temporary channels should have sufficient capacity to convey 1.6 cfs/acre of contributing drainage area or the peak flow from a 2-year frequency storm event (2.25 cfs/acre or 5-year storm event in special protection watersheds).
- b. Permanent channels should be able to convey 2.75 cfs/acre or the peak flow from a 10-year storm.

Any channel remaining as part of site restoration must be lined with an erosion resistant lining.

10. **Sediment Traps** - Sediment traps are needed when a sufficient vegetative filter strip is not present and slope lengths exceed the maximum allowable for sediment barriers. Wherever sediment traps are proposed, they should meet the following criteria:
- a. Sediment traps may not be located within stream channels.
  - b. The maximum permissible drainage area is 5.0 acres.
  - c. Sediment traps must have a minimum storage volume of 2,000 cubic feet for each acre of contributing drainage area (disturbed and undisturbed). 700 cubic feet/acre is considered sediment storage. 1300 cubic feet/acre is considered settling volume.
  - d. The minimum flow length (L) through the trap is 10 feet.
  - e. Sediment traps must discharge to stable, erosion resistant areas and not create offsite stormwater problems.
  - f. The minimum trap storage depth is 2.0 feet (1 foot for sediment storage and 1 foot dewatering zone).
  - g. Traps must be able to dewater the settling volume completely.
  - h. The maximum constructed embankment height is 5.0 feet.
  - i. Maximum embankment side slope = 2:1 (H:V)
  - j. Minimum freeboard above the maximum design water level is 12".
  - k. Embankment spillways criteria:
    - (1) The width of the spillway (in feet) shall be at least 2 times the number of acres contributing to the drainage area, or 2 times the height of the spillway crest, whichever is greater. Wherever traps discharge directly to a wetland, the spillway width should be at least 4 times the number of tributary acres.
    - (2) The minimum spillway crest elevation is the elevation at which the required 2,000 cubic feet per contributing drainage acre storage capacity is provided.
    - (3) Maximum spillway side slope = 2:1 (H:V)
    - (4) Minimum rock size construction of the spillway is R-3. Note: The entire spillway should be constructed with rock (see Figure 27).
    - (5) The inside face of the spillway should be covered with a 6" (minimum) thick layer of filter stone (maximum size = AASHTO #57).
    - (6) Filter fabric should be securely staked on top of the filter stone up to the Sediment Storage Elevation. Any excess fabric should be staked to the bottom of the trap.

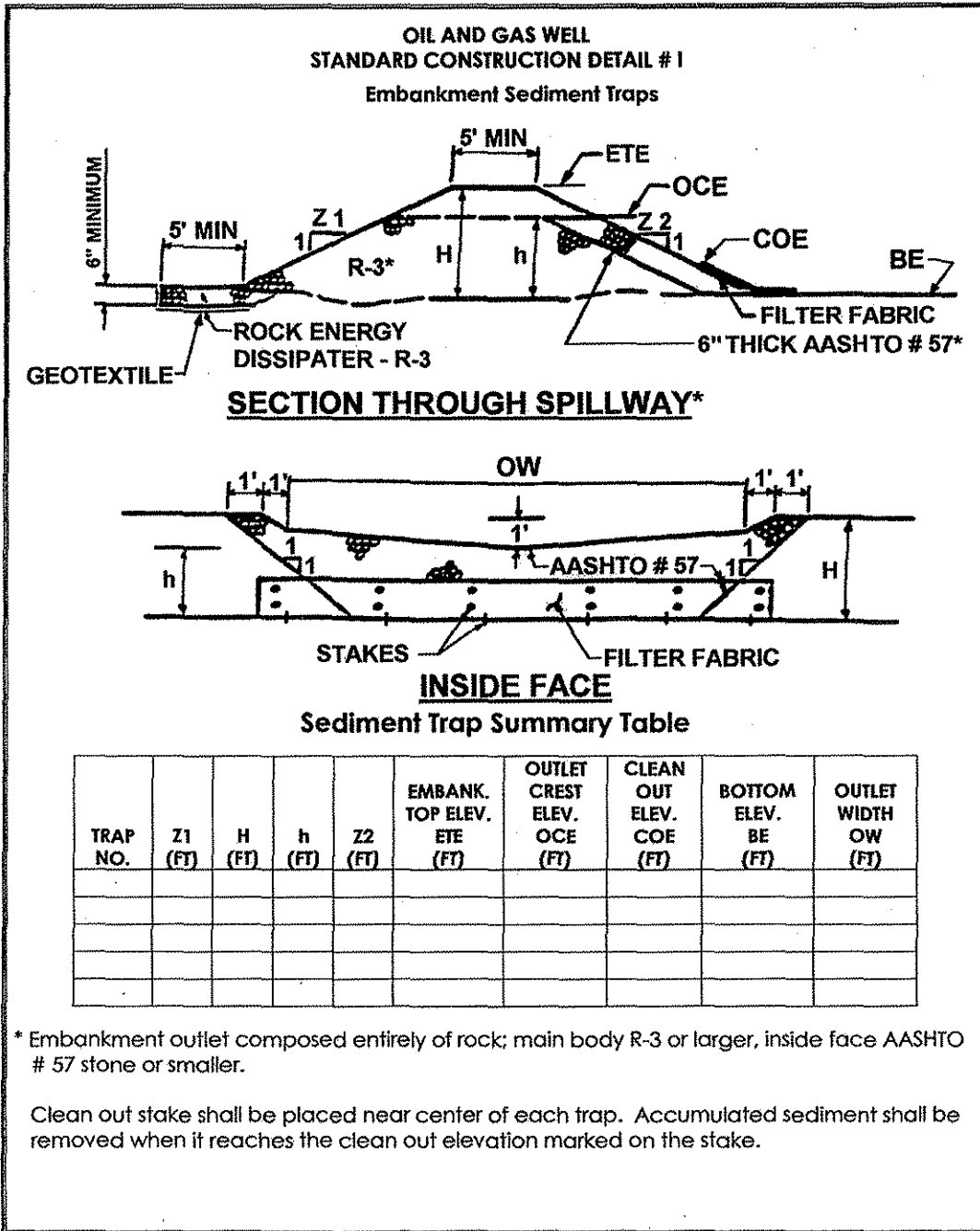

12. **Road-side Ditches** - Side ditches are used to convey runoff to culverts, waterbars or broad-based dips for crowned or insloped roadways. If the ditch is not located in an erosion-resistant soil, it should be lined with an appropriate nonerosive material such as vegetation, rock riprap, geotextile, or other material.

Protective Lining is not required in roadside ditches where the following conditions apply:

- The ditches do not carry perennial flow.
- Cross pipes have been installed in accordance with Table 4-5 and Figures 4-6, 4-7 and 4-9. Rock filters (see paragraph 20) have been installed at all inlets to culverts where the distance to the stream is less than 200 feet.
- Roadside ditches which carry perennial flow should be lined with the properly sized riprap. (See pages 16 – 34 of DEP's Erosion & Sediment Pollution Control Program Manual for information about proper sizing of riprap.)

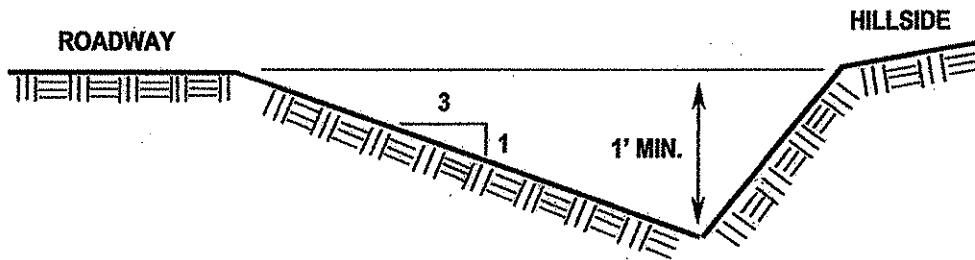

Figure 4-5. Cross Section of a Typical Side Ditch

Figure 4-6. Cross-section of Insloping Roadway at Culvert

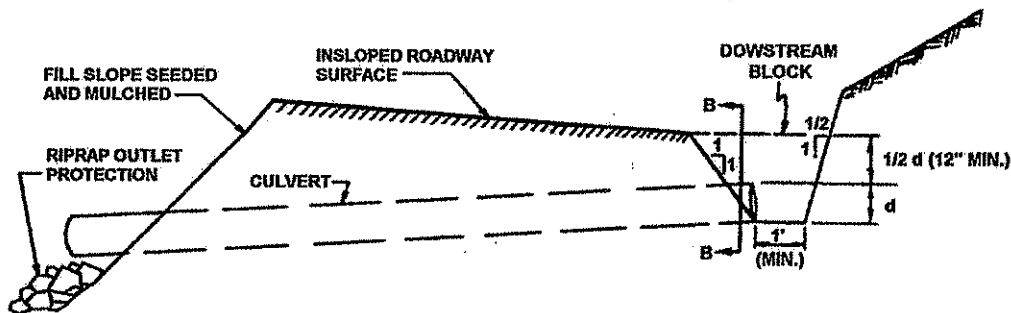
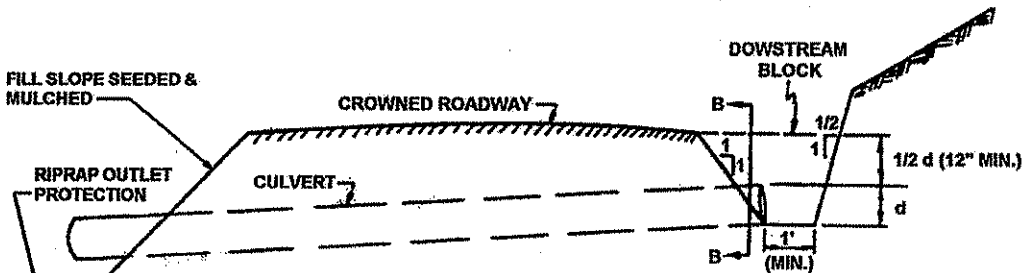
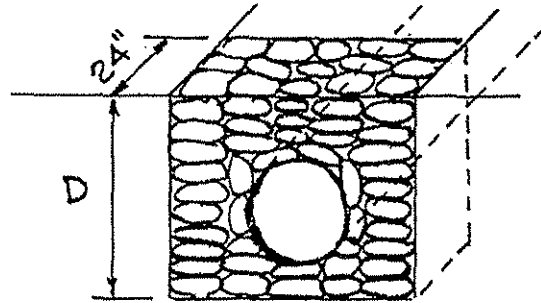

Figure 4-7. Cross-section of Crowned Roadway at Culvert



# TRENCH BREAKERS / TRENCH PLUGS

TRENCH BREAKERS/TRENCH PLUGS SHOULD BE INSTALLED IN ALL UTILITY LINE TRENCHES PER TABLE 3. TABLE 3. INDICATES THE REQUIRED SPACING AND MATERIALS FOR THE TRENCH BREAKERS/TRENCH PLUGS.



D= TRENCH DEPTH TO BOTTOM OF TRENCH

## SECTION VIEW NOT TO SCALE

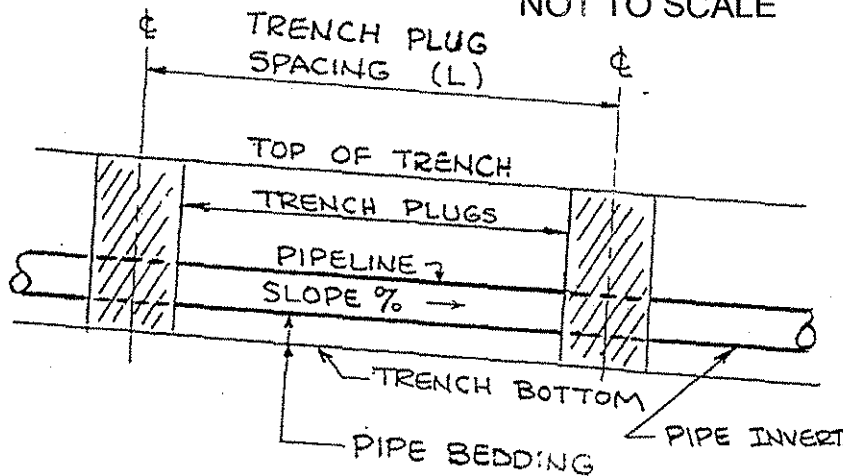

## ELEVATION NOT TO SCALE

TABLE 3. REQUIRED SPACING AND MATERIALS FOR TRENCH BREAKERS/TRENCH PLUGS

TRENCH SLOPE	SPACING (L) IN FEET	PLUG MATERIAL
0-5%	*	*
5-15%	500	**EARTH FILLED SACKS
15-25%	300	**EARTH FILLED SACKS
25-35-%	200	**EARTH FILLED SACKS
35-100%	100	**EARTH FILLED SACKS
OVER 100%	50	CEMENT FILLED BAGS (WETTED)
OR		MORTARED STONE

\* TRENCH BREAKERS/TRENCH PLUGS (EARTH FILLED SACKS) ARE REQUIRED AT ALL STREAM/RIVER/WATERBODY AND WETLAND CROSSINGS REGARDLESS OF TRENCH SLOPE.

\*\* TO ENSURE PROPER TOPSOIL CONSERVATION, TOPSOIL SHOULD NOT

**OIL AND GAS WELL  
STANDARD CONSTRUCTION DETAIL # II  
Straw Bale Barriers**

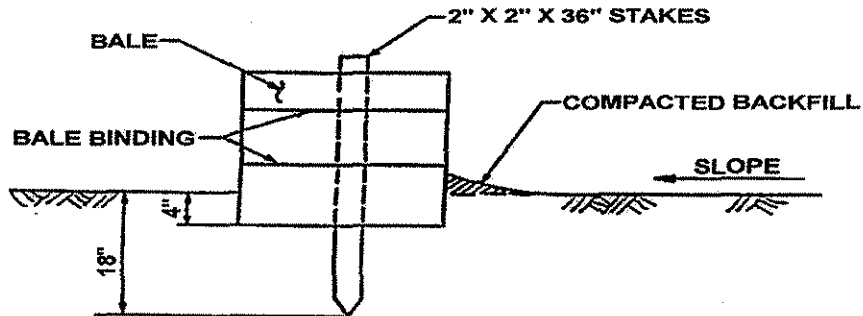

Straw Bale Barriers should not be used for more than 3 months or in areas where rock prevents full and uniform anchoring of the bales.

Bales should be installed in an anchoring trench. Two support stakes should be driven through each bale to the depth of 18" below the ground surface. The excavated soil should be backfilled and compacted on the upslope side of the bales.

Straw Bale Barriers shall be placed at existing level grade. Both ends of the barrier shall be extended at least 8 feet up slope at 45 degrees to the main barrier alignment.

Sediment shall be removed when accumulations reach 1/3 the above ground height of the barrier.

Any section of Straw Bale Barrier which has been undermined or topped shall be immediately replaced with a Rock Filter Outlet. See Standard Construction Detail # VII.

**1. EXCAVATE THE TRENCH.**



**2. PLACE AND STAKE STRAW BALES.**

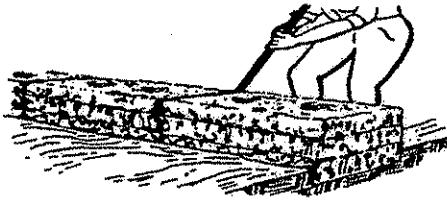

**2. WEDGE LOOSE STRAW BETWEEN  
BALES.**

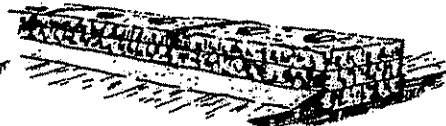

**4. BACKFILL AND COMPACT THE  
EXCAVATED SOIL. (ANCHOR TOE)**

**OIL AND GAS WELL  
STANDARD CONSTRUCTION DETAIL # III  
Standard Filter Fabric Fence (18" High)**

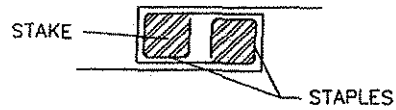

JOINING FENCE SECTIONS

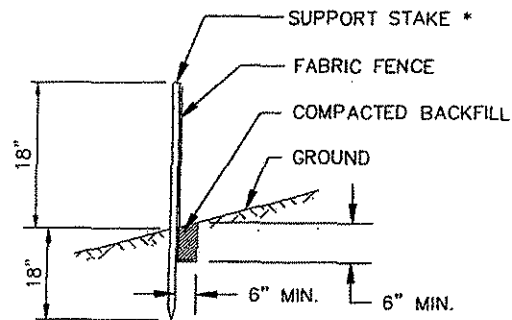

\*Stakes spaced @ 8' maximum. Use 2"x 2" wood or equivalent steel stakes.

Filter Fabric Fence must be placed at level existing grade. Both ends of the barrier must be extended at least 8 feet up slope at 45 degrees to the main barrier alignment.

Sediment must be removed when accumulations reach 1/2 the above ground height of the fence.

Any section of Filter fabric fence which has been undermined or topped must be immediately replaced with a Rock Filter Outlet. See Standard Construction Detail # VII.

**OIL AND GAS WELL  
STANDARD CONSTRUCTION DETAIL # IV  
Reinforced Filter Fabric Fence (30" High)**

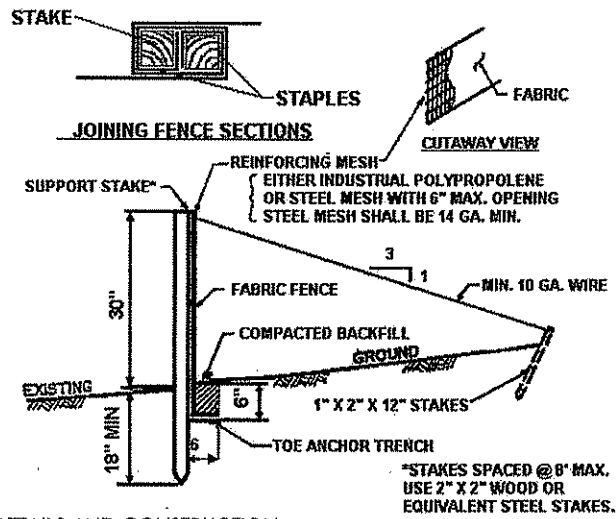

NOTE: SHOW ALL DETAILS AND CONSTRUCTION DIMENSIONS ON PLAN DRAWINGS.

Filter fabric fence must be installed at existing level grade. Both ends of each fence section must be extended at least 8 feet upslope at 45 degrees to the main fence alignment.

Sediment must be removed where accumulations reach 1/2 the above ground height of the fence.

Any fence section which has been undermined or topped must be immediately replaced with a rock filter outlet. See Standard Construction Detail # VII.

**OIL AND GAS WELL  
STANDARD CONSTRUCTION DETAIL # V  
Filter Fabric Fence Reinforced by Staked Straw Bales**

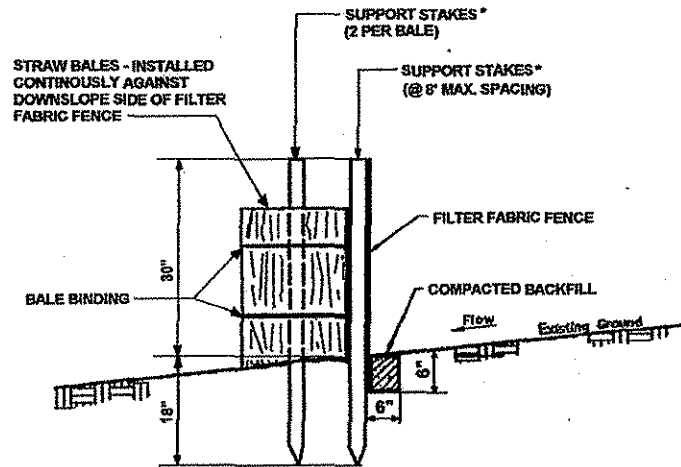

\*USE 2" X 2" WOOD OR  
EQUIVALENT STEEL STAKES.

Filter fabric fence must be installed at existing level grade. Both ends of each fence section must be extended at least 8 feet upslope at 45 degrees to the main fence alignment.

Sediment must be removed where accumulations reach 1/2 the above ground height of the fence.

Any fence section which has been undermined or topped must be immediately replaced with a rock filter outlet. See Standard Construction Detail # VII.

### ACCESS ROAD CROSSING OF PAVED ROAD

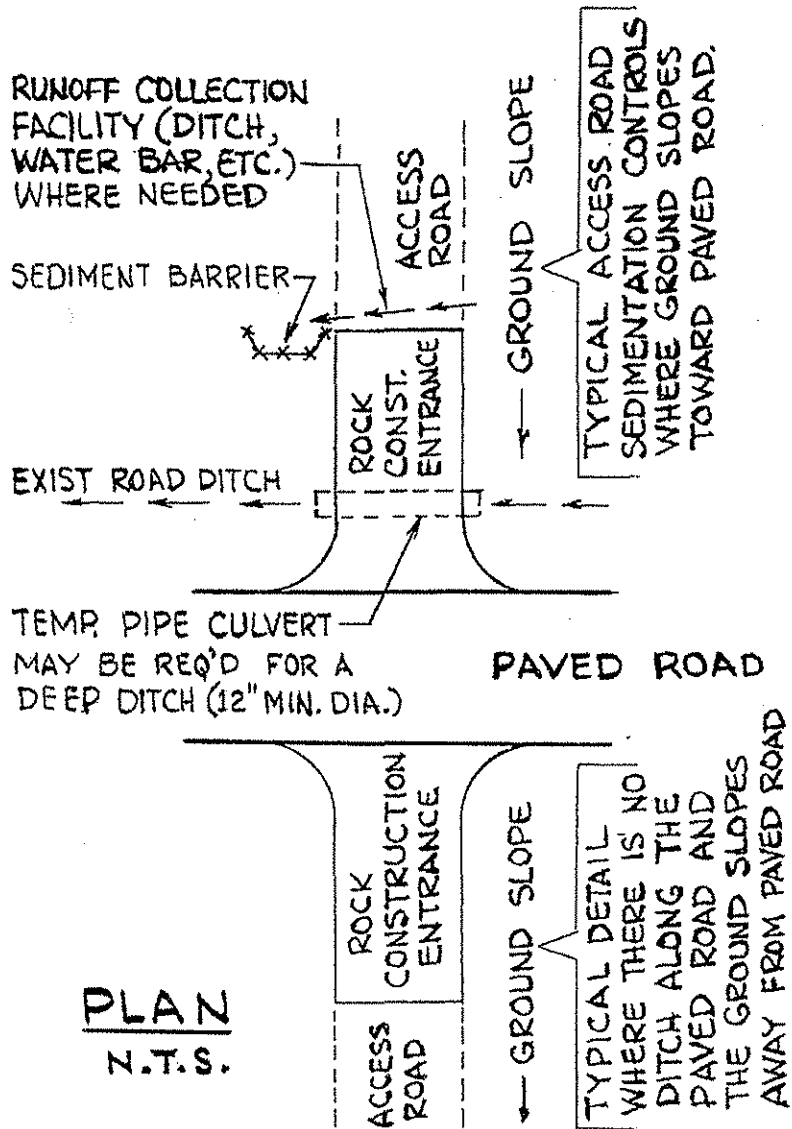

**PLAN**  
N.T.S.

THE RUNOFF COLLECTION FACILITY AND THE SEDIMENT REMOVAL FACILITY SHOULD BE PROVIDED FOR ACCESS ROAD CROSSINGS OF UNPAVED ROADS WHERE THE GROUND SLOPES TOWARD THE UNPAVED ROAD.

Figure 4-9a. Typical Culvert Installation

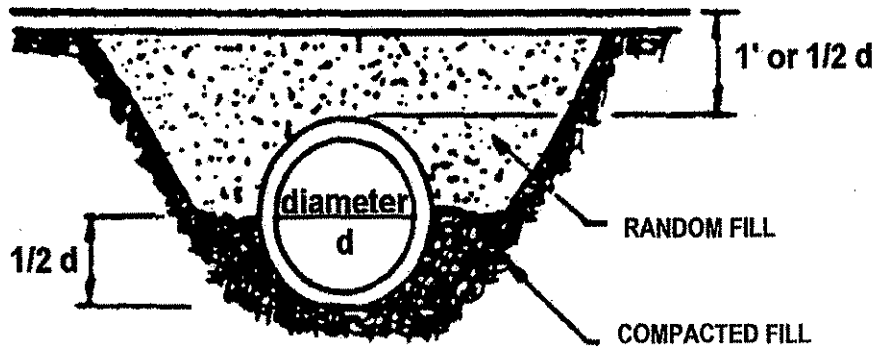
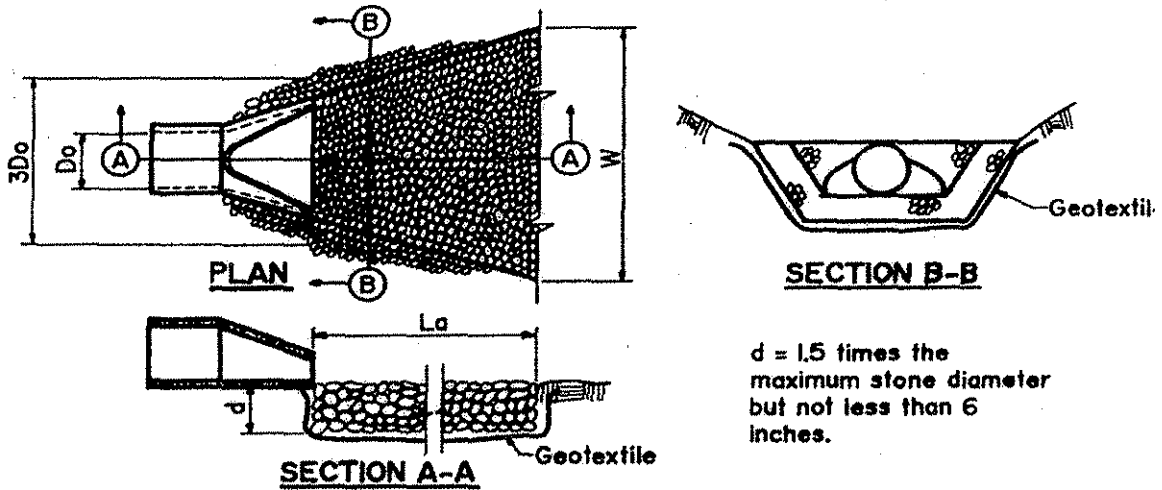

Figure 4-9b. Riprap Apron Outlet Protection

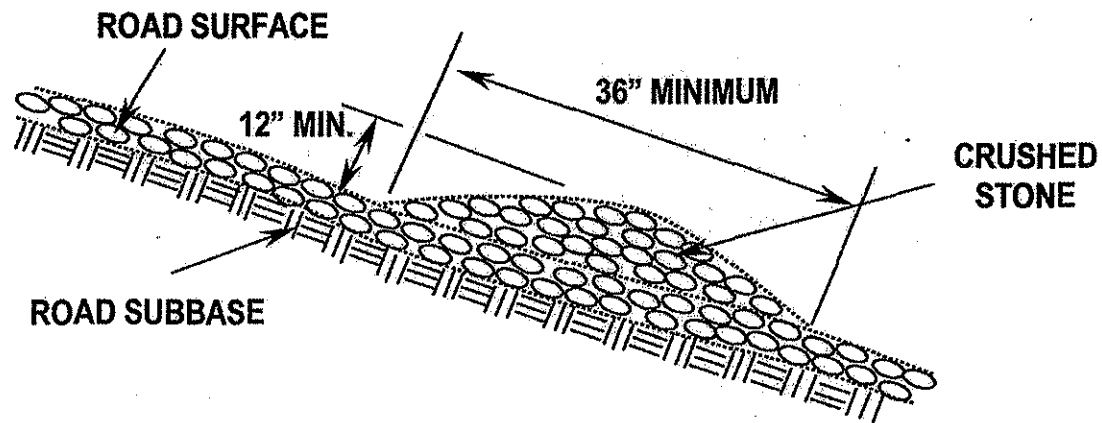

**Table 4-6. Culvert Minimum Sizes and Spacing**

ROAD GRADE	CULVERT SPACING	CULVERT SIZE (inches)					
		LENGTH OF SIDE HILL DRAINAGE (feet)					
		100-200	300	400	500	600	600+
S	L						
%	feet						
2	500	12	15	15	15	15	18
3	400	12	15	15	15	15	18
4	350	12	15	15	15	15	18
5-6	300	12	12	15	15	15	18
7-8	250	12	12	12	15	15	15
9-11	200	12	12	12	12	15	15
12-13	150	12	12	12	12	12	15
14+	100	12	12	12	12	12	15

<b>Grade of road (percent)</b>	<b>Distance between waterbar (feet)</b>
2	250
5	135
10	80
15	60
20	45
25	40
30	35
40	30

**Figure 4-11. Waterbar Dimensions**



**FIGURE 32**  
**Waterbar Installation**

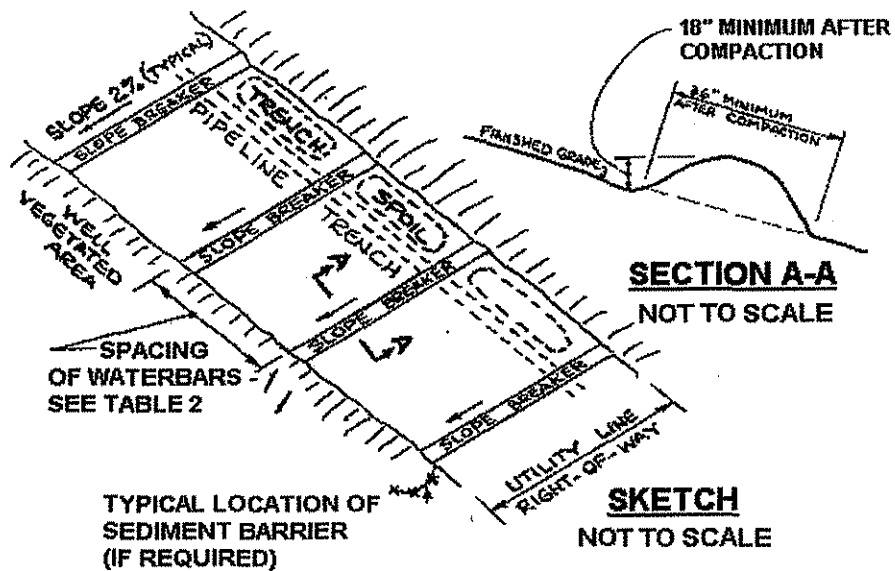

Required Spacing for Permanent Waterbars	
Percent Slope	Spacing (FT)
< 5	*
5 - 15	150
15 - 30	100
> 30	50

\* Permanent waterbars are required at all stream, river, and other water-body crossings as well as upslope from roadway and railroad cut slopes. Otherwise not required.

Water bars (slope breakers, interceptor dikes) should be installed across the entire right-of-way on all slopes greater than 5%.

Waterbars should be constructed at a slope of 2% and discharge to a well-vegetated area. Waterbars should not discharge into an open trench. Waterbars should be oriented so that the discharge does not flow back onto the right-of-way. Obstructions, (e.g. straw bales, silt fence, rock filters, etc.) should not be placed in any waterbars. Where needed, they should be located below the discharge end of the waterbar.

19. Stream Crossings

Figure 4-13. Temporary Stream Crossing

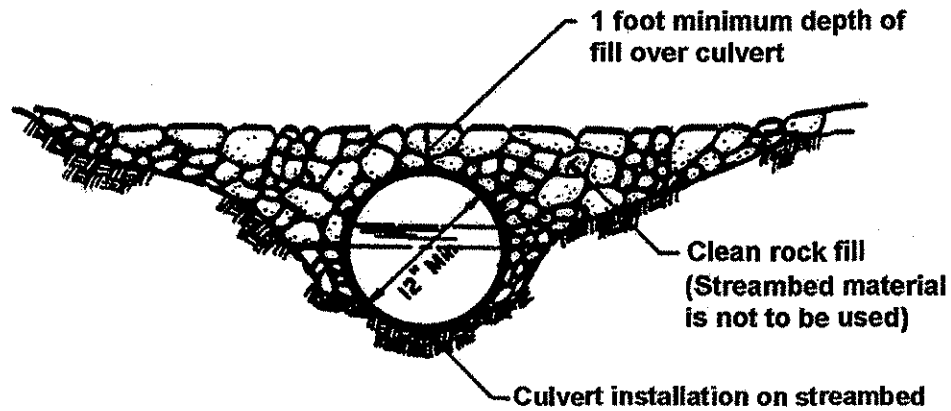

An 8" thick layer of AASHTO #1 stone shall be maintained for a minimum distance of 50' from top of bank on both sides of stream channel.

Figure 4-14. Temporary Stream Crossing – Multiple Pipes Detail

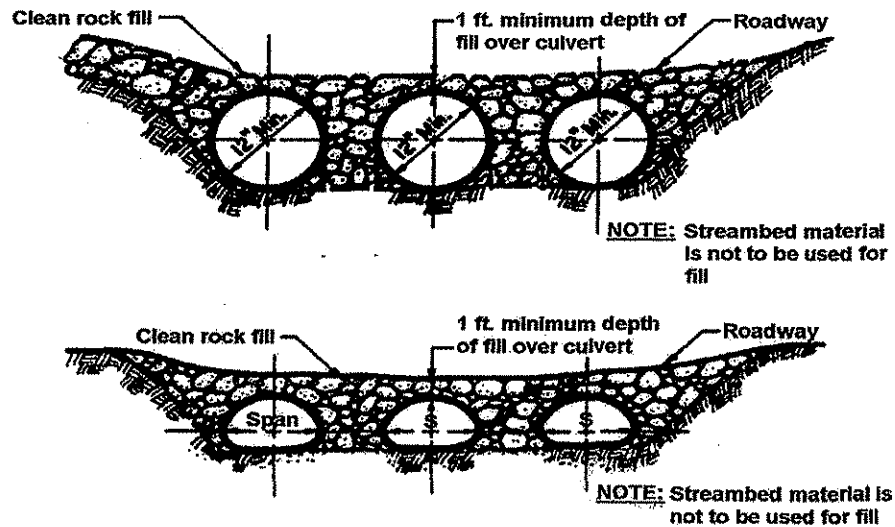

An 8" thick layer of AASHTO #1 stone shall be maintained for a minimum distance of 50' from top of bank on both sides of stream channel.

## SWALE/DITCH/CHANNEL/WATERWAY CROSSING

ADEQUATELY SIZED TEMPORARY PIPE  
CULVERT (MIN. 12" DIA.) REQUIRED FOR  
TRENCHES LEFT OPEN MORE THAN ONE  
WORKING DAY

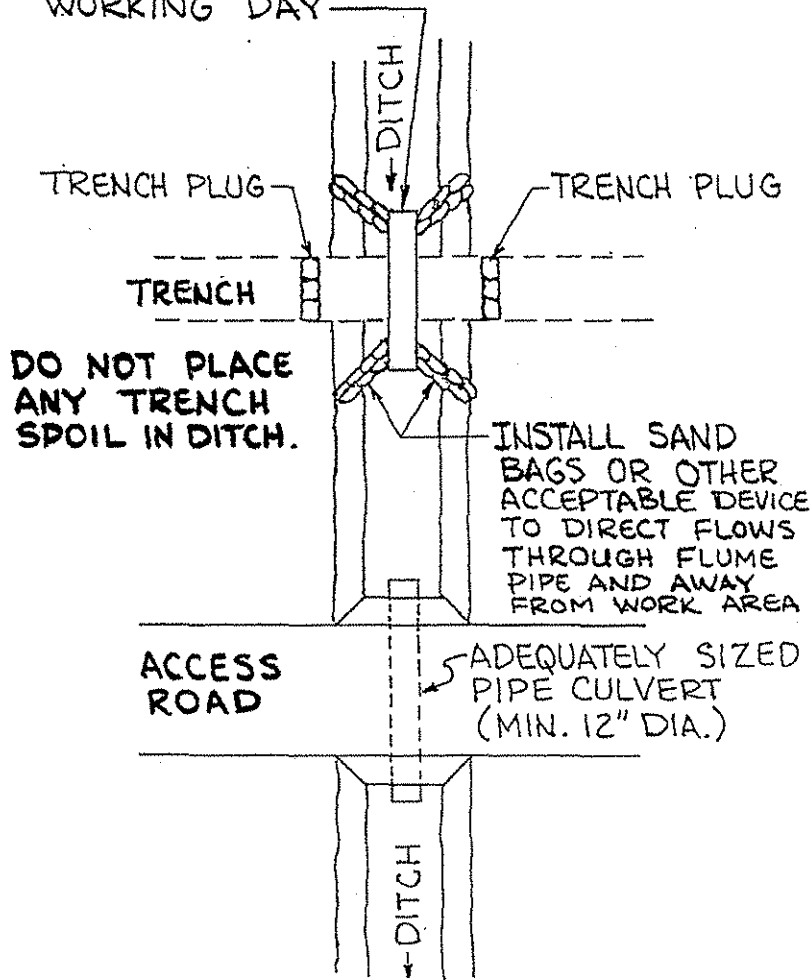

### PLAN NOT TO SCALE

Adequately sized pipe culverts should be installed for access roads at all locations where access roads cross a swale/ditch/channel or waterway whether or not flowing water is encountered.

An adequately sized flume pipe or culvert properly "sand bagged" to direct flows through the flume pipe and away from the work area should be installed across the utility line trench at all locations where the trench crosses a swale/ditch/channel or waterway. Trench spoil should not be placed in any swale/ditch/channel or waterway. If flow exists in the swale/ditch/channel or waterway at the time of trenching, then the pipe flume or culvert properly "sand bagged" must be installed prior, to the trenching operation. If the swale/ditch/ channel or waterway is dry at the time of trenching, then the pipe flume or culvert and sandbags may be installed immediately after the trench is completed in that area. If the utility line trench IS excavated, the utility line installed and the trench backfilled on the same day, then a pipe flume or culvert is not needed providing that the swale/ditch/channel or waterway is dry and is reshaped and stabilized immediately.



## 22. UTILITY LINE STREAM CROSSING WITH PIPE FLUME

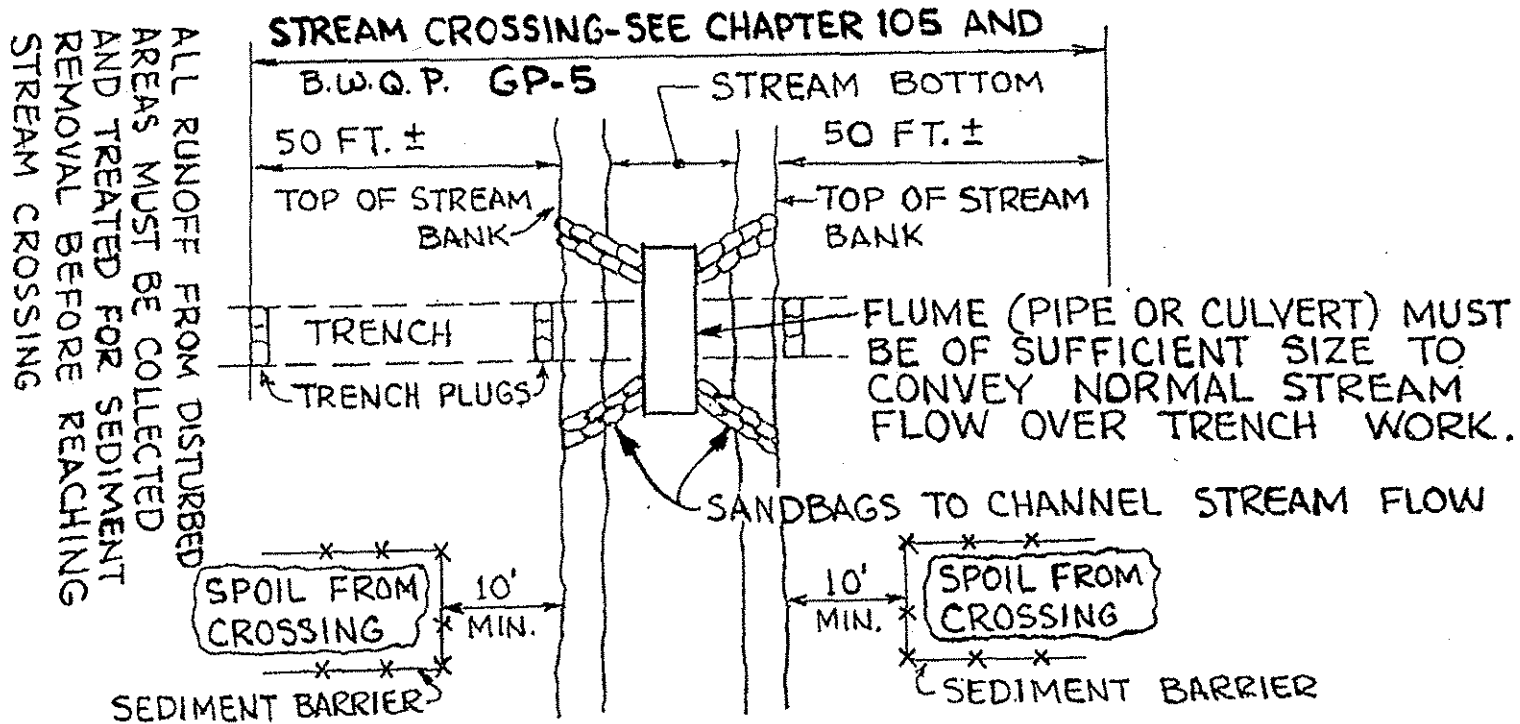

ALL RUNOFF FROM DISTURBED AREAS MUST BE COLLECTED AND TREATED FOR SEDIMENT REMOVAL BEFORE REACHING STREAM CROSSING

**PLAN**  
NOT TO SCALE

**These comments apply to both "utility line stream crossing with pipe flume" and "utility line stream crossing with dam and pumping".**

Utility line stream crossings are considered to begin (or end) 50 feet back from the top of the stream bank on both sides of the stream per the department's chapter 1 05 definition. Pipelines with the pipe joints assembled/made in the trench should maintain a 50 ft. Buffer on both sides of the stream until the stream crossing commences. Large diameter steel pipelines with welded joints where the pipe joints are welded while the pipeline is out of the trench should maintain a 10 ft. Buffer on both sides of the stream until the stream crossing commences.

A utility line stream crossing of a stream 10 feet in (bottom) width or less should be completed within 72 hours (from start to finish) including the trench backfilling, stabilization of stream banks and stabilization of the area 50 feet back from the top of each stream bank.

Facilities for removing sediment from pumped water should be available at the utility line stream crossing site before trenching commences and maintained until trench backfilling is completed.

Assembly areas, temporary equipment and non-hazardous material storage areas should be located at least 50 feet back from the top of stream bank.

Hazardous or pollutive material storage areas should be located at least 100 feet back from the top of stream bank.

All excess excavated material shall be immediately removed from stream crossing.

### 23. UTILITY LINE STREAM CROSSING WITH DAM AND PUMPING

ALL RUNOFF FROM DISTURBED AREAS MUST BE COLLECTED AND TREATED FOR SEDIMENT REMOVAL BEFORE REACHING STREAM CROSSING

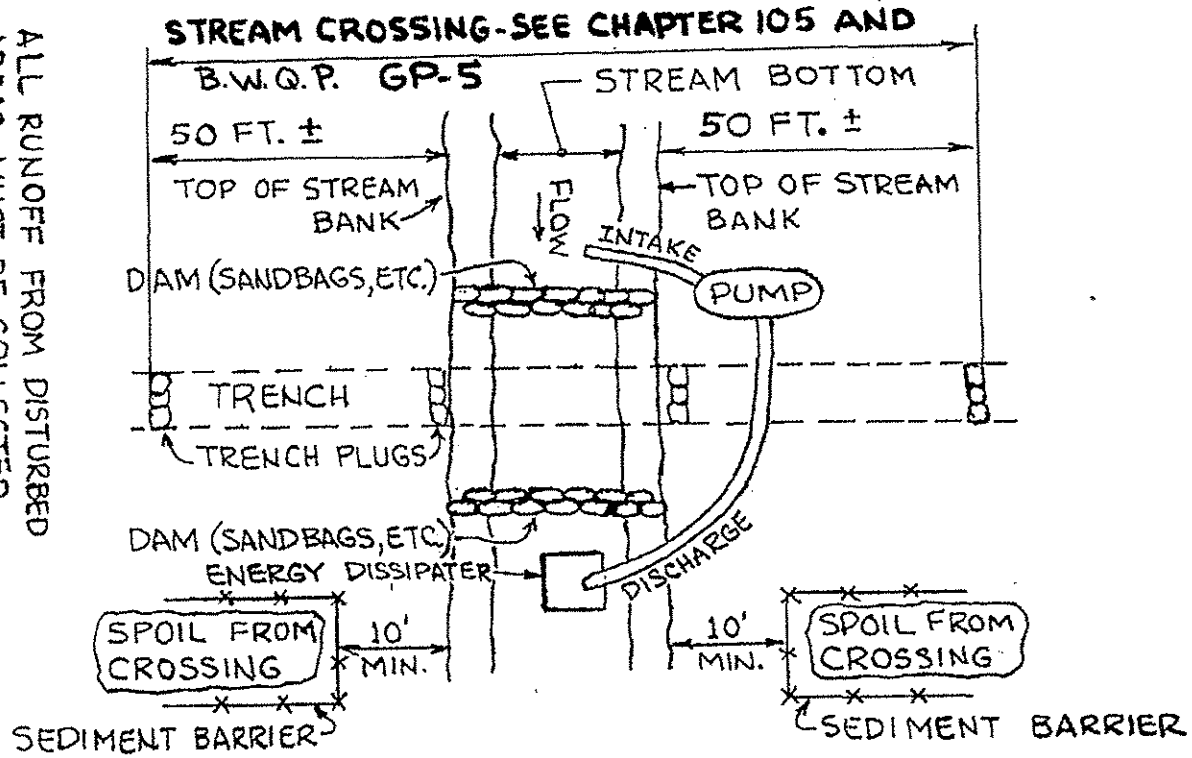

A STANDBY PUMP SHOULD BE AVAILABLE AT THE STREAM CROSSING SITE DURING PUMPING OPERATIONS.

**PLAN**  
NOT TO SCALE

**ACCESS ROAD WETLAND CROSSING**

Removal of trees, tree stumps, brush and vegetation should be kept to a minimum in the wetland. Grading should be limited to the area directly over the trench to the extent possible. Where clearing of trees and vegetation is required for the equipment access areas, the tree and vegetation root mass is to remain undisturbed. Vegetation may be cut at/ near the ground line and should be removed from the wetland. Trees should be cut above the ground line with the stumps left in place, except where removal is required for safety reasons.

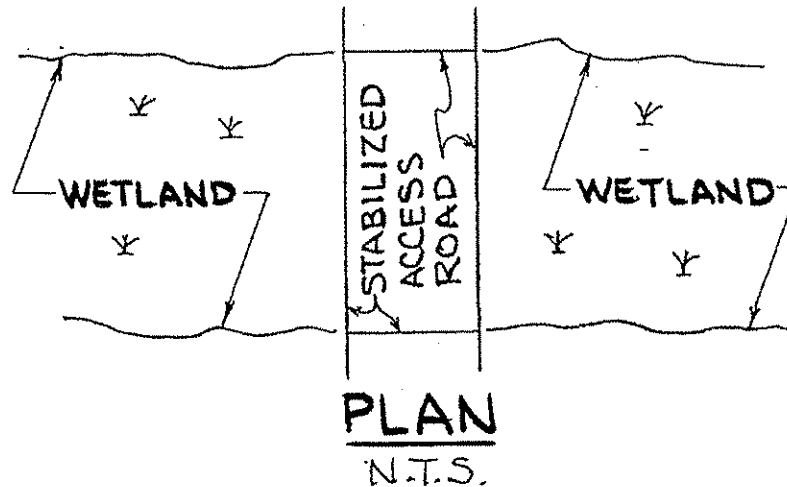

The movement of vehicles and/or equipment across wetlands, should be kept to an absolute minimum. The access road width should be kept to a minimum and be stabilized as specified in the erosion and sedimentation control plan. The access road may be stabilized by placing gravel or crushed aggregate upon geotextile fabric, or by placing timber rip rap or prefabricated swamp mats. The timber rip rap or prefabricated swamp mats should not be more than 2 layers thick. A properly designed plank road may also be utilized. Dirt, rock, stumps or brush shall not be used to stabilize the wetland. All material used to stabilize the access road must be removed from the wetland when utility construction is completed.

Crossing stream channels with any type of construction vehicle or equipment is unacceptable. A temporary road stream crossing should be installed before any construction equipment or vehicle crosses a stream channel. A temporary road stream crossing will usually consist of a pipe culvert or culverts or a temporary bridge. The use of fords for temporary stream crossings is not acceptable. Only clean rock fill (usually R-3 or larger rock) should be used in the stream channel where fill is needed (for pipe culverts, etc.) The roadway surface may be choked with AASHTO NO.1 rock. Rock smaller than AASHTO NO.1 is not recommended. Rock should be provided for the access road surface for a minimum distance of 10 feet back from the top of the stream bank on both sides of the stream. Surface runoff from the access road should be collected and treated for the removal of sediment before entering the stream. The access road runoff should be collected at a point 50 feet back from the top of the stream bank and conveyed to a sediment removal facility. If a water bar (or swale ditch) across the access road is used to collect road runoff it must be designed and constructed to withstand vehicle/ equipment traffic (without breach) and maintain its flow carrying capacity. Mechanical reinforcement of such water bars or swale ditches is recommended. Access road surface runoff should also be collected at the edge of the roadway surface rock and conveyed to a sediment removal facility.

## SEEDING

The Department recommends the use of the **Penn State Erosion Control & Conservation Plantings on Noncropland** Manual as a reference to use for selection of species, seed specifications, mixtures, liming and fertilizing, time of seeding, and seeding methods. The publication is available from county Cooperative Extension Service offices. Specifications for these items may also be obtained from Penn DOT's Publication # 408, Section 804 or by contacting the applicable county conservation district. Upon selection of a reference, that reference must be used to provide all specifications for seeding, mulching, and soil amendments. Indicate the reference being used in the plan submittal.

Seeding rates are stated as pounds per acre (lb/A) of pure live seed (PLS). Pure Live Seed is the product of the percentage of pure seed times the percentage of germination divided by 100 (e.g.  $[85\% \text{ pure seed} \times 72\% \text{ germination}] \div 100 = 61\% \text{ PLS}$ ).

Actual Seeding Rates may be determined by dividing the PLS seeding rate by the %PLS shown on the seed tag, or calculated as shown above (e.g. for a PLS seeding rate of 12 lb/A from a seedlot with a PLS of 35%, the actual seeding rate is equal to  $12 \div 0.35 = 34.3 \text{ lb/A}$ ). If More Than One Species is used, indicate the application rate for each species.

The Department also recommends that soil testing be done prior to seeding and mulching to determine the proper soil amendments and application rates for the proposed seed mixture(s). Soil test kits are inexpensive and may be obtained from the county Cooperative Extension Service offices. When done properly, soil tests can actually save money that would otherwise be lost on improper soil amendments, unsuccessful seeding, and damage caused by erosion of unstabilized areas. In the absence of a soil test, soil amendments should be added at the rates specified by the selected seeding reference.

Site conditions such as soil limitations, steepness of slope, and proposed land use should be considered in selecting seed mixtures.

Tables contained in the county Soil Surveys published by the USDA Natural Resources Conservation Service provide valuable information regarding soil use limitations. Soils designated as "infertile", "wet", "droughty", "acid", etc. should be given special attention when selecting seed mixtures. Table 15 identifies plant species which are tolerant and intolerant of these soil conditions.

Wherever seeding is to be done on steep slopes ( $\geq 3:1$ ), seed mixtures should be selected that are appropriate for steep slopes. Table 4 in the **Erosion Control & Conservation Plantings on Noncropland** and Table A (Section 804.2(b)) in Penn DOT's publication 408 identify seed mixtures suitable for steep slope conditions.

Fill slopes should be seeded and mulched at regular vertical increments (15' max.) as the fill is being constructed. This will allow the bottom of the fill to move toward stabilization while work continues on the upper portion, making final stabilization easier to achieve and providing some vegetative buffering at the bottom of the slope.

In critical areas (e.g. adjacent to or within 50' of streams, ponds, or wetlands) consideration should be given to providing a protective blanket for seeded areas. Mulch with netting or protective blankets should be provided for seeded areas on slopes steeper than 3:1.

Table 4 in the **Erosion Control & Conservation Plantings on Noncropland** Manual as well as PennDOT's publication 408 provide information regarding seed selection for various proposed land uses.

When wetland areas are temporarily disturbed, isolate and stockpile topsoil for replacement after grading is completed. If temporary vegetative stabilization is necessary, apply annual ryegrass at the rate of 48# PLS/acre. Mulch using clean straw at the rate of 3T /acre. No soil amendments are recommended.

Show all seeding, mulching, and soil amendment specifications on a detail sheet. References to a standard seed mixture are not acceptable.

The beginning and ending of the germination season for each of the proposed seed mixtures should be provided as well as directions for temporary stabilization of disturbed areas that achieve finished grade during non-germinating seasons.

Vegetated areas shall be considered permanently stabilized when a uniform 70% vegetative cover of erosion resistant perennial species has been achieved, or the disturbed area is covered with an acceptable BMP which permanently minimizes accelerated erosion and sedimentation. Until such time as this standard is achieved, interim stabilization measures and temporary erosion and sediment control BMPs that are used to treat project runoff may not be removed.

### **Recommended Seeding Mixture and Rate**

Seed Application Rate – 39 lbs/acre

- Content - 77% Tall Fescue  
 - 15% Birdsfoot Trefoil  
 - 8% Redtop

Ground Limestone – apply at 3 to 4 tons per acre

- Fertilizer – Nitrogen (N) 100 lbs/acre  
 - Phosphorus (P) 200 lbs/acre  
 - Potassium (P) 200 lbs/acre

Other rates and mixtures will give similar results. Additional information on seeding and fertilizing may be obtained from the U.S. Department of Agriculture or the Soil Conservation Service.

**TABLE 15**  
**Plant Tolerances of Soil Limitation Factors**

Species	Growth Habit <sup>1</sup>	Tolerates				Minimum Seed Specifications <sup>3</sup>				
		Wet Soil	Dry Site	Low Fertility	Acid Soil (pH 5-5.5) <sup>2</sup>	Purity (%)	Ready Germ (%)	Hard Seed (%)	Total Germ (%)	Seeds/lb (1,000s)
<b>Warm-Season Grasses</b>										
Deertongue	bunch	yes	yes	yes	yes	95	75		75	250
Weeping lovegrass	bunch	no	yes	yes	yes	97	75		75	1,500
Switchgrass <sup>4</sup>	bunch	yes	yes	yes	yes	(60 PLS)			390	
Big bluestem	bunch	no	yes	yes	yes	(60 PLS)			150	
<b>Cool-Season Grasses</b>										
Tall Fescue	bunch	yes	no	yes	no	95	80		80	227
Redtop	sod	yes	yes	yes	yes	92	80		80	5,000
Fine fescues	sod	no	no	yes	no	95	80		80	400
Perennial ryegrass	bunch	yes	no	no	no	95	85		85	227
Annual ryegrass	bunch	yes	no	yes	no	95	85		85	227
Kentucky bluegrass	sod	no	no	no	no	85	75		75	2,200
Reed canarygrass	sod	yes	yes	yes	no	95	70		70	520
Orchardgrass	bunch	yes	yes	yes	yes	95	80		80	654
Timothy	bunch	yes	no	yes	yes	95	80		80	1,230
Smooth brome	sod	no	yes	yes	no	95	80		80	136
<b>Legumes<sup>5</sup></b>										
Crownvetch	sod	no	yes	yes	no	98	40	30	65	120
Birdsfoot trefoil <sup>6</sup>	bunch	yes	no	yes	yes	98	60	20	80	400
Flatpea	sod	no	no	yes	yes	98	55	20	75	10
Serecia lespedeza	bunch	no	yes	yes	yes	98	60	20	80	335
<b>Cereals</b>										
Winter wheat	bunch	no	no	no	no	98	85		85	15
Winter rye	bunch	no	no	yes	yes	98	85		85	18
Spring oats	bunch	no	no	no	no	98	85		85	13
Sundangrass	bunch	no	yes	no	no	98	85		85	55
Japanese millet	bunch	yes	no	yes	yes	98	80		80	155

<sup>1</sup> Growth habit refers to the ability of the species to either form a dense sod by vegetative means (stolons, rhizomes, or roots) or remain in a bunch or single plant form. If seeded heavily enough, even bunch formers can produce a very dense stand. This is sometimes called a sod, but not in the sense of a sod formed by vegetative means.

<sup>2</sup> Once established, plants may grow at a somewhat lower pH, but cover generally is only adequate at pH 6.0 or above.

<sup>3</sup> *Minimum seedlots are truly minimum, and seedlots to be used for revegetation purposes should equal or exceed these standards.* Thus, deertongue grass should germinate 75% or better. Crownvetch should have at least 40% readily germinable seed and 30% hard seed. Commonly, seedlots are available that equal or exceed minimum specifications. Remember that disturbed sites are adverse for plant establishment. Ready germination refers to seed that germinates during the period of the germination test and that would be expected, if conditions are favorable, to germinate rapidly when planted. The opposite of ready germination is dormant seed, of which hard seed is one type.

<sup>4</sup> Switchgrass seed is sold only on the basis of pure live seed (PLS).

<sup>5</sup> Need specific legume inoculant. Inoculant suitable for garden peas and sweetpeas usually is satisfactory for flatpea.

<sup>6</sup> Birdsfoot trefoil is adapted over the entire state, except in the extreme southeast where crown and root rots may injure stands.

**MULCHING** - Mulches absorb rainfall impact, increase the rate of infiltration, reduce soil moisture loss due to evaporation, moderate soil temperatures, provide a suitable environment for germination, and protect the seedling from intense sunlight. All seeded areas should be mulched to minimize the potential for failure to establish an adequate vegetative cover. Mulching may also be used as a temporary stabilization of disturbed areas in non-germinating seasons.

**FIGURE 19**  
**Straw Mulch At Various Rates Of Application**

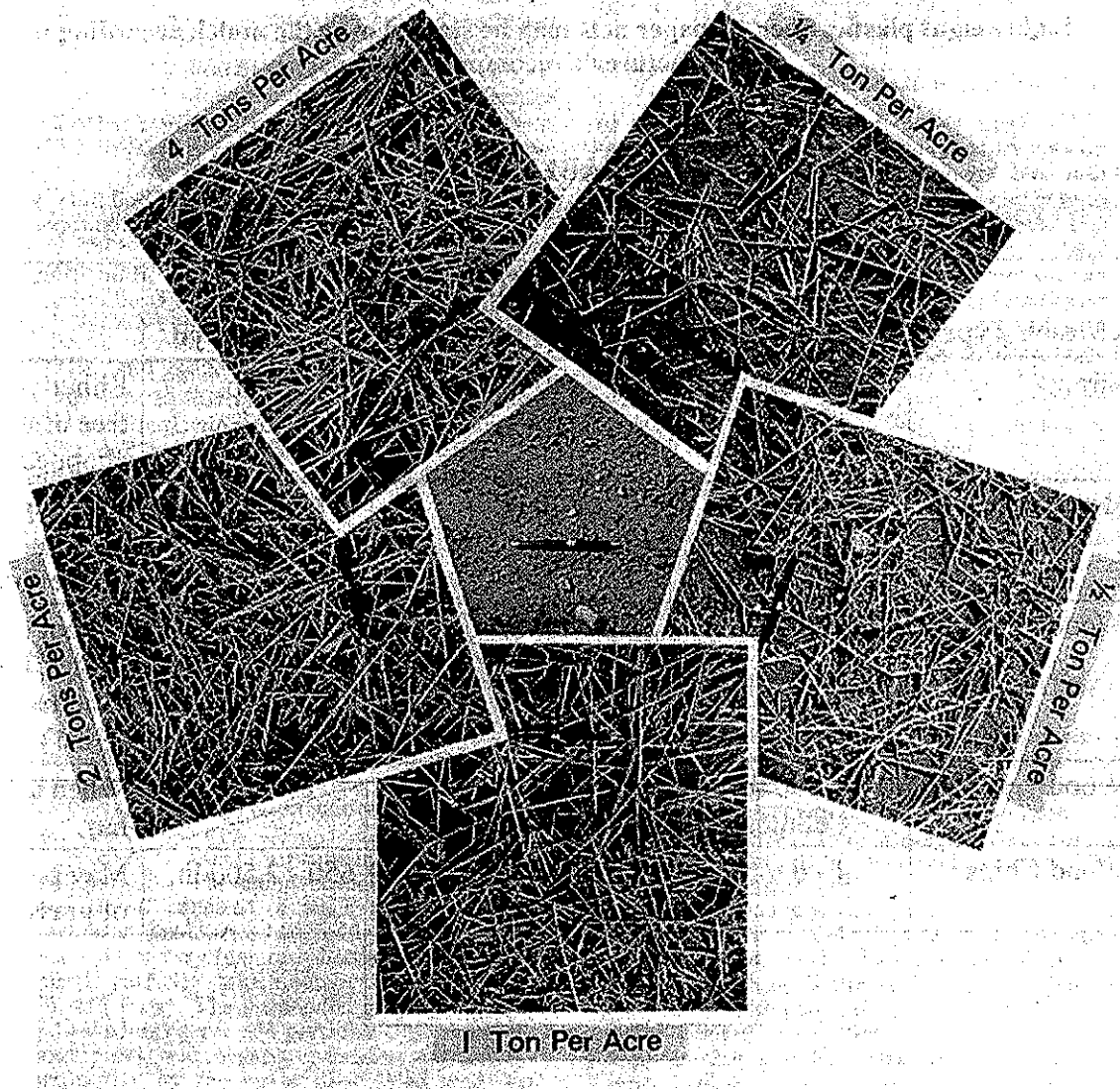

Apply mulches at the rates shown in **Table 16**

Straw and hay mulch should be anchored immediately after application to prevent being windblown. A tractor-drawn implement may be used to “crimp” the straw or hay into the soil. This method is limited to slopes no steeper than 3:1. The machinery should be

operated on the contour. (Note: Crimping of hay or straw by running over it with tracked machinery is not recommended.)

Asphalt, either emulsified or cut-back, containing no solvents or other diluting agents toxic to plant or animal life, uniformly applied at the rate of 31 gallons per 1000 sq. yd. may be used to tack mulch.

Synthetic Binders (chemical binders) may be used as recommended by the manufacturer to anchor mulch provided sufficient documentation is provided to show they are non-toxic to native plant and animal species.

Lightweight plastic, fiber, or paper nets may be stapled over the mulch according to manufacturer's recommendations.

**TABLE 16**  
**Mulch Application Rates**

Mulch Type	Application Rate (Min.)			Notes
	Per Acre	Per 1,000 sq. ft.	Per 1,000 sq. yd.	
Straw	3 tons	140 lb.	1,240 lb.	Either wheat or oat straw, free of weeds, not chopped or finely broken
Hay	3 tons	140 lb.	1,240 lb.	Timothy, mixed clover and timothy or other native forage grasses
Wood Cellulose	1,500 lb.	35 lb.	310 lb.	Do not use alone in winter, during hot and dry weather or on steep slopes ( $\geq 3:1$ )
Wood Cellulose	1,000 lb.	25 lb.	210 lb.	When used over straw or hay
Wood Chips	4 - 6 tons	185 - 275 lb.	1,650 - 2,500 lb.	May prevent germination of grasses and legumes